

## COMOSS EVB Series Transceiver Test Board

### Data Sheet

**EVB(Evaluation Broad) is a Fast Ethernet on Layer 2 POFs (Plastic Optical Fiber) or Transceivers Test Kit.**

### Overview

The use of plastic optical fiber (POF) as a physical layer for Fast Ethernet is on the rise. COMOSS EVB Series allows the user to examine a data link over POF and to test the operation of the fiber optic transceivers.

Each evaluation board carries the POF transceiver components in a through-hole of OPTOLOCK® connector. The electrical input and output lines from the transceiver are brought out to SMA connectors. The input accepts an LVDS/CML or PECL data source such as a Bit Error Rate Tester (BERT), Pattern Generator, or other signal source. A full-duplex Step Index POF cable links the optical signal to the second board. The receive side of the transceiver generates LVDS/CMS - compatible differential output data signals. The boards are capable of full-duplex operation. In addition to the data input and output signals, the transmitter side also has a Rex input to control the optical power. For normal operation, this input may be tied to ground. The receiver side also provides a Signal Detect (SD) output. If not required, this output may be left open circuit.

## Content

<b>CONTENT .....</b>	<b>2</b>
<b>DESCRIPTION .....</b>	<b>3</b>
<b>POWER SUPPLIES.....</b>	<b>3</b>
<b>DATA INPUT/ OUTPUT .....</b>	<b>4</b>
<b>CIRCUITS SCHEMATIC.....</b>	<b>4</b>
<b>PCB LAYOUT .....</b>	<b>5</b>
<b>TYPICAL TEST LAYOUT.....</b>	<b>6</b>
<b>TYPICAL TEST DATA/ EYE DIAGRAMS .....</b>	<b>7</b>
<b>ORDER INFORMATION.....</b>	<b>8</b>

## Description



The use of plastic optical fiber (POF) as a physical layer for Fast Ethernet is on the rise. COMOSS EVB Series Kit allows the user to examine a data link over POF and to test the operation of the fiber optic transceivers. This evaluation kit includes two evaluation boards, two DC power supplies and 100Megabit 50 meters (GI-POF Gigabit large cord cable is 30 meters) Step Index POF cable with SMI plugs at each end. Each board includes a Tx-Rx pair in an OPTOLOCK<sup>®</sup> or SMI socket. The PCBs have been carefully laid out and tested to demonstrate the performance of the COMOSS Fast Ethernet Transceiver OPTOLOCK<sup>®</sup> or SMI over POF.

## Power Supplies

Two DC power supplies are provided for power up. The power supplies have multiple plugs to accommodate the majority of wall sockets available worldwide, and accept inputs from 100 to 240 volts AC, 50 to 60 Hz. The evaluation board can be powered by any standard 5 DC power jack which feeds a DC power regulator to provide Vcc at 3.3V to the components on the board.

## Data Input/ Output

Input and output data require SMA-style connectors. The input signals Din and Inverse. Din are AC coupled with a 100Ω resistor across the differential inputs on the FOT side of the coupling capacitors.

## Circuits Schematic

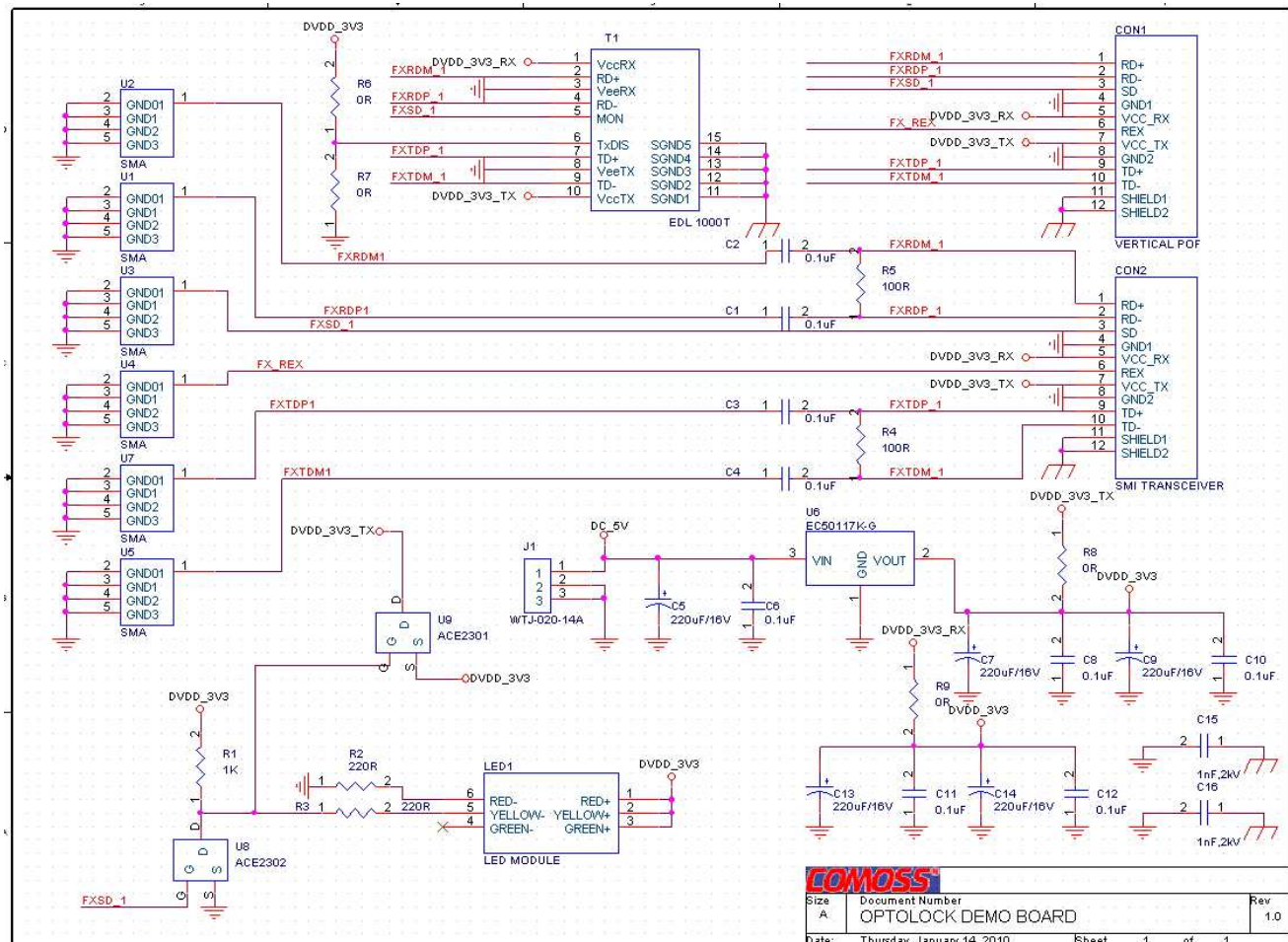

## PCB Layout

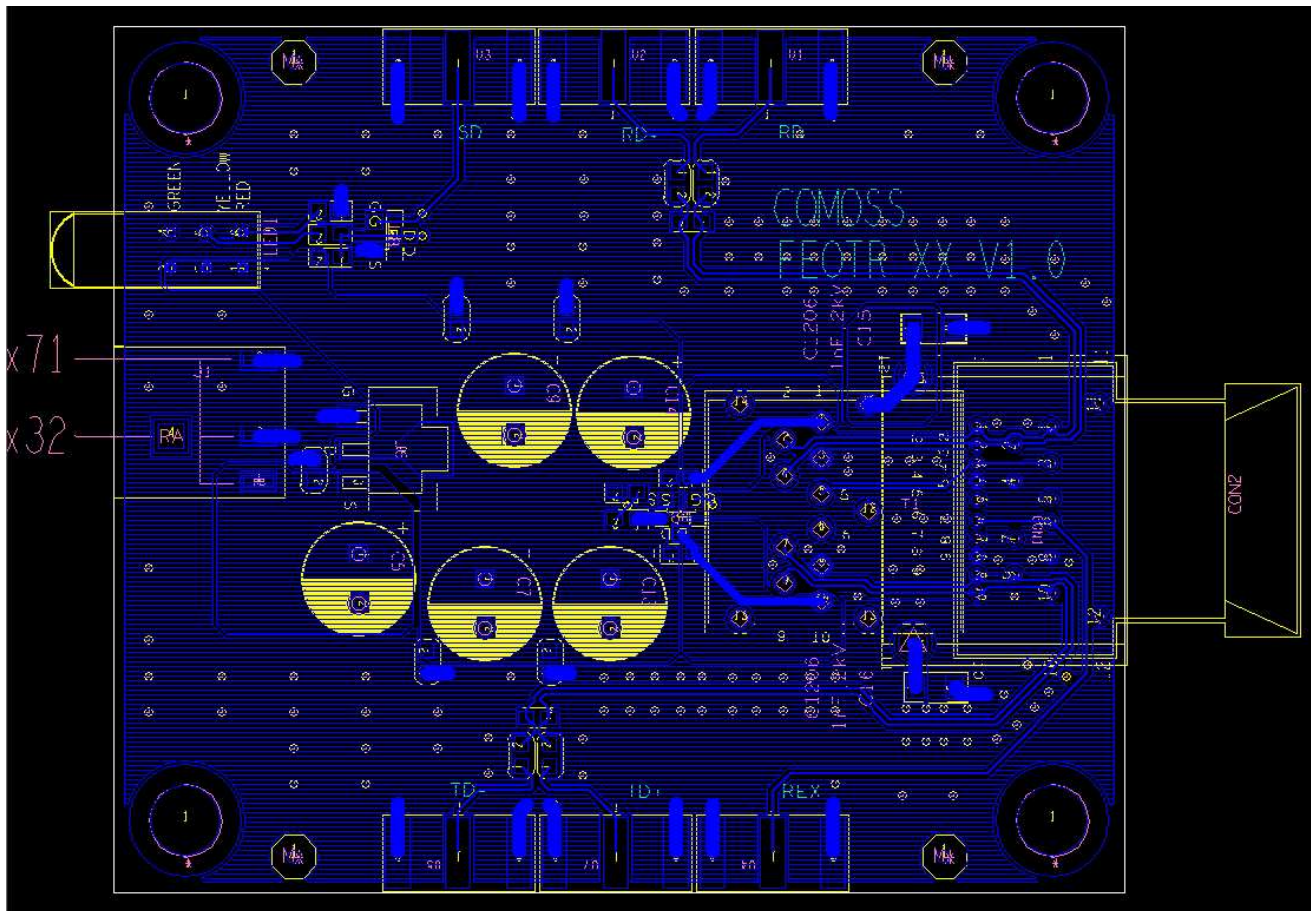

## Typical Test Layout

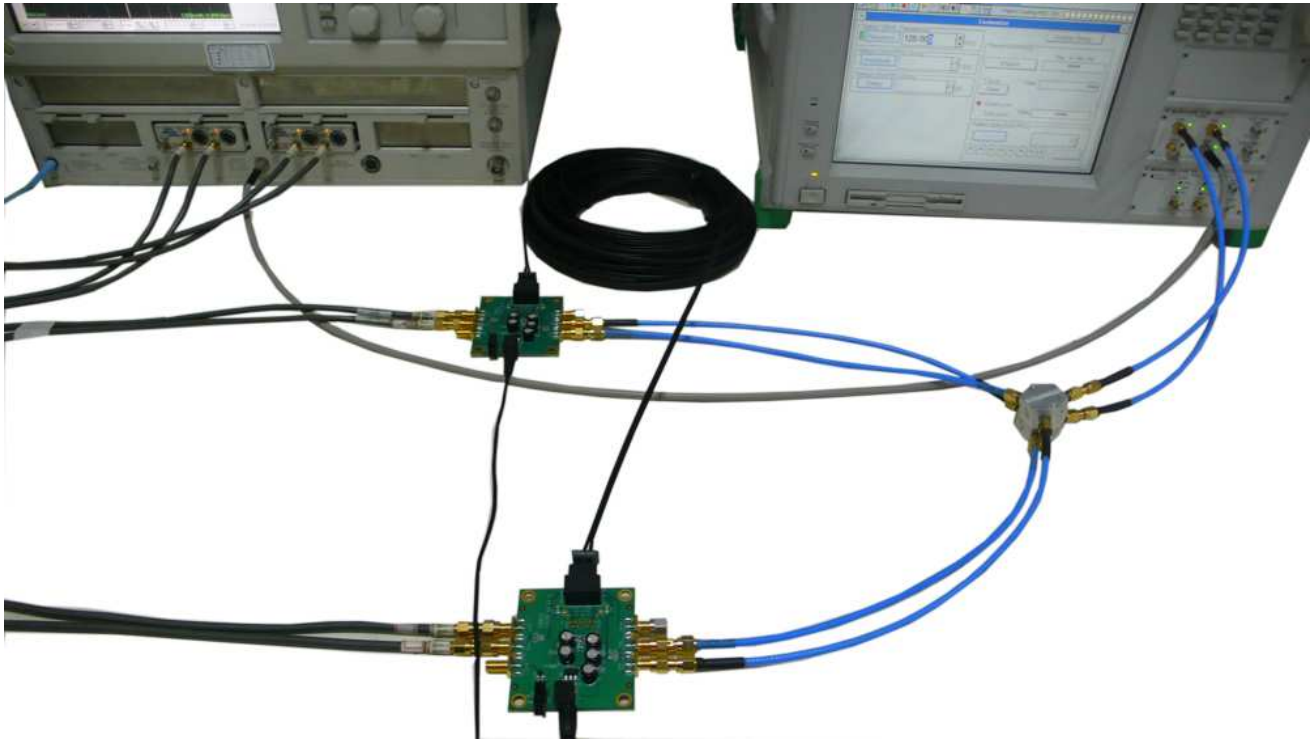

## Typical Test Data/ Eye Diagrams

The following eye diagrams were taken with a pair of evaluation boards (as shown in Figure 4) using a pattern generator running at 125 Mbps, providing an LVDS PRBS<sup>7</sup> signal to Data In+ and Data In-. A suitable oscilloscope captured the electrical output from the receiver on the evaluation board. The data was recorded at room temperature of approximately 25 degree Centigrade.

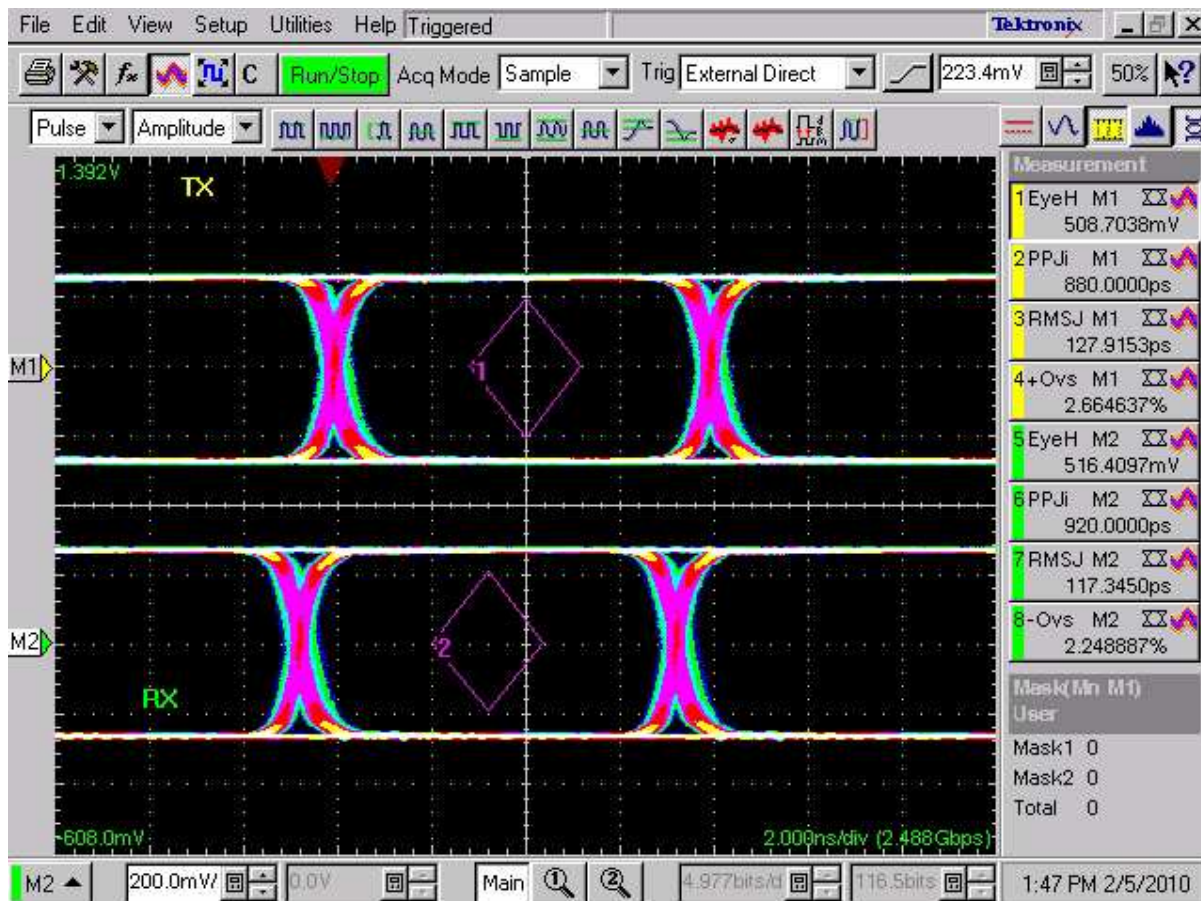

## Order Information

FEOTR - O X  
(1) (3)

### (2) Converter Type :

- O: OPTOLOCK<sup>®</sup> POF interface.

### (3) Connector Type :

- 1: One 2.2mm OPTOLOCK<sup>®</sup> Vertical Transceiver.
- 2: One 2.2mm OPTOLOCK<sup>®</sup> Transceiver.
- 3: One 1.5mm OPTOLOCK<sup>®</sup> Transceiver.
- 4: One 2.2mm Gigabit OPTOLOCK<sup>®</sup> Large cord Transceiver (include 30 meters GI-POF Large cord Cable.).

**P.S. OPTOCLOCK<sup>®</sup> is a registered by FIRECOMMS Ltd.**